

# CTCW Constant Tension Center Wind Card

**Instruction Manual**  
Model D10337-000

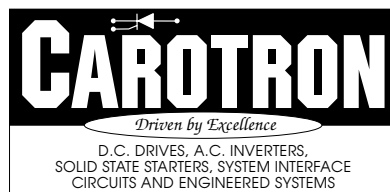



3204 Rocky River Road  
Heath Springs, SC 29058  
Phone: (803) 286-8614  
FAX: (803) 286-6063



# Table of Contents

1. General Description . . . . .	2
2. Specifications . . . . .	2
3. Theory of Operation . . . . .	2
4. Description of Adjustments & Potentiometers . . . . .	3
5. Jumper Selection . . . . .	4
6. Adjustment Procedure . . . . .	4
7. Prints . . . . .	7
7.1 C10432 - Dimension and Adjustment Location, CTCW . . . . .	7
7.2 D10335 - Schematic, CTCW Control Board . . . . .	8
7.3 D10337 - Assembly, CTCW Control Board . . . . .	9
7.4 C10373 - Connections, CTCW and RCP200 Series Regen Control . . . . .	10
7.5 C10421 - Connections, CTCW and ADP100 Series Control . . . . .	11
7.6 C11823 - Connections, CTCW with ISOLATED WINDER DRIVE . . . . .	12

# 1

## General Description

The Carotron CTCW (Constant Tension Center Wind) Control is designed for use with a torque mode drive to provide constant tension or taper tension control of a center driven winder. Web tension is regulated by controlling motor torque through varying levels of material roll diameter, line speed and line acceleration rate. These diameter, friction and inertia compensating torque signals are summed with other torque signals to further provide control of core tension, taper tension,

stall tension and even Winder motor RPM when in the JOG mode.

The CTCW can accept an external diameter signal or can calculate diameter from Line and Winder speed signals by an internal Radius Computer with memory.

A +10 VDC reference is available for a direct contact rider roll compensator to measure diameter.

The Line Speed signal input is isolated to allow use of existing feedback or process tachometers.

# 2

## Specifications

### A.C. Input

115 VAC, 50/60 Hz, 11 VA max., internally fused

### Signal Inputs

- Line speed signal, isolated, 240 VDC maximum in four ranges
- Winder speed signal, 240 VDC maximum in four ranges
- Diameter signal, + 10 VDC maximum
- Tension pot. input, 1K ohm minimum resistance
- Winder armature or tachometer signal, 90 and 180 VDC ranges

### Build Range

- 10 to 1 nominal constant tension range: greater with taper tension

### Control Relays

- Jog relay, 115 VAC @ .1 VA, customer contact required
- Stall tension relay, 115 VAC @ .1 VA, customer contact required
- Memory reset relay, 115 VAC @ .1 VA, customer contact required

### Signal Outputs

- Torque mode- 10 VDC maximum torque reference
- Jog mode- 3 VDC maximum, closed loop speed reference equivalent to 500 RPM motor speed, adjustable

# 3

## Theory of Operation

### Tension/Torque Control

The main function of a CTCW (Constant Tension Center Winder) is to provide rotational torque at a level that will keep the material tension level constant through ever changing conditions of Winder loading. The source of torque in this case, a D.C. motor, will produce torque output that is directly proportional to its Armature Current level. The strength of the field, which also affects torque, is held constant by a fixed voltage supply for shunt wound motors or by use of a permanent magnet motor. The Carotron CTCW then controls tension by providing a complete torque reference to a motor armature current regulator.

### Diameter Compensation

Normally the greatest change in required torque is caused by the increase in roll diameter as material is wound up. For Constant Tension, the torque must increase in direct proportion to the diameter increase. The CTCW can accept a directly sensed diameter signal or it can calculate diameter with a radius computer by comparing the line speed to the winder RPM's which decrease as roll diameter (and circumference) increase. This signal can be trimmed with an external tension potentiometer and is used as part of the total winder torque reference.

To maintain speed based diameter levels dur-

ing stops the CTCW has a 8 bit digital memory. It remembers the diameter based torque that is required at "stop" for constant tension and at "start" to help accelerate larger rolls up to speed.

### Taper Control

In some cases a decreasing tension or taper tension is desirable to prevent telescoping and/or wrinkling of inner layers of material. The torque/diameter signal should be between a proportionally increasing signal and a constant torque signal. The Carotron unit can be adjusted to provide taper tension starting at any point in the roll build and up to 100% taper.

At times winders must supply torque to compensate for loading not directly related to the material being wound or its diameter increase. Mechanical friction and inertia are examples.

### Friction Compensation

Torque must be supplied to overcome friction in the mechanics of the drive train - simply to bring an empty winder up to speed. Usually the friction loading increases with speed.

### Inertia Compensation

Matching acceleration rate of the winder to the acceleration rate of the line requires inertia compensating torque during the acceleration. Some materials at larger diameters can significantly increase the total load inertia and require increased compensating torque. The CTCW can supply rate control as well as fixed or diameter based level control to its inertia compensation.

### Core Tension

Even when beginning a new roll on the winder, the diameter of the core must be considered. Some direct diameter sensing methods supply zero signal at core. The CTCW provides a Core Tension pot. to set a minimum torque level with newly threaded core.

### Stall Tension

When it is desirable to stop or "park" the winder for a period of time but maintain a constant torque from the winder, stall tension can be selected. Energizing the stall tension relay by a contact closure will set a fixed torque level on the web to prevent back-up, sagging, etc.

Switching to the stall mode is usually more appropriate for setting a parking tension level that is lower than the core tension or any stored memory signal plus core tension.

### Jog mode

A slow and steady speed is best when aligning and threading material on the winder. Carotron's CTCW supplies this in the jog mode by converting operation of the winder drive from torque control to velocity control.

Note: A 50 or 100V/1000 RPM winder motor tachometer can be used at TB2-17 for the JOG speed feedback or the armature voltage from 90 or 180V un-isolated model winder controls can be used.

## 4 Description of Jumpers, Potentiometers

### Jumpers

- Jumper J1 selects one of four Line voltage input ranges.
- Jumper J2 No Longer Used
- Jumper J3 position determines whether the inertia compensating signal is drawn from a fixed voltage supply or a diameter dependent voltage supply.
- Jumper J4 selects one of four winder voltage input ranges.
- Jumper J5 is selected to match the type of winder controller, i.e. regenerative or non-regenerative. It and J6 only affect jog mode operation.
- Jumper J6 controls jog mode feedback voltage scaling based on the winder motor armature rating.

### Potentiometers

NOTE: All potentiometers are multiturn cermet types.

- P1, Line Cal, along with P12 further scales the Line speed signal within the range selected by jumper J1.
- P2, Taper Torque, is used in conjunction with P3 and sets the level of tension tapering torque versus diameter.
- P3, Taper Setpoint, is used in conjunction with P2 and sets the diameter level at which tapering torque begins.
- P4, Dia/Torque Level, controls the torque versus diameter level.
- P5, Jog Speed, adjusts the winder motor RPM when the jog relay is energized.

- P6, Stall Tension, when selected by the stall tension relay sets a winder torque level based solely on this pot setting.
- P7, Computer Scaling, sets the diameter/torque level based on the ratio of line speed to winder motor speed.
- P8, MIN Range sets the trim range of the external TENSION pot.
- P9, Core Tension, adjusts the minimum torque level supplied by the winder when all other torque signals are at zero.
- P10, Dia/Supply Setpoint, operation is selected by J3 and sets the diameter level at which an inertia compensating signal supply starts to

- appear. P13 and P14 affect use of this signal.
- P11, Friction Comp, trims the amount of line speed based torque that is supplied.
- P12, Line Offset, is used with P1 and sets the internal line speed signal to zero with minimum external line input.
- P13, WK-Squared Inertia Comp, is used with P14 and provides coarse adjustment of the inertia compensating torque that is based on the line acceleration rate.
- P14, Rate Response, is used with P13 and gives finer control of the rate determined inertia compensation.

## 5 Jumper Selection

- J1- The output rating of the line speed signal source determines the position of J1. Select the voltage range closest to but not less than the maximum line speed signal.
- J2 - Not used.
- J3 - Place J3 in the FIXED position. The fixed level Inertia Comp supply is simpler to set up and is suitable for most applications.

- J4 - The output rating of the winder speed signal source determines the position of J4. Select the voltage range closest to but not less than the maximum winder speed signal.
- J5 - Select the position of J5 depending on the type of motor controller used on the winder, i.e. regenerative or non-regenerative.
- J6 - Set to correspond with motor armature or tachometer voltage rating.

## 6 Adjustment Procedure

### **WARNING!!!**

**THIS CIRCUIT IS ELECTRICALLY HOT AND PRESENTS A SHOCK HAZARD**

The CTCW circuit is directly connected to the WINDER motor control which may not be isolated from the AC line

### **WARNING!!!**

**DO NOT USE GROUNDED TEST EQUIPMENT OR TIE ANY CIRCUITRY TO EARTH OR CHASSIS GROUND!!!**

NOTE: All voltage measurements should be made with respect to circuit common at TP5 or TB2-5, 8, 13 or 15.

Any Winder armature current measurements should be made with a D.C. ammeter connected in series.

### 1. Pre-sets

- Adjust P3 and P8 to full CW.
- Adjust P2, P9 and P13 to full CCW.
- Adjust the external TENSION pot. to minimum, full CCW.
- Temporarily install a jumper between terminals TB1-3 & 4. This keeps the Computer MEMORY reset.

NOTE: It is assumed that the radius computer will be used to supply the diameter signal. If an externally generated diameter signal is selected by SW1, delete steps 3 and 4 of the following procedure.

### 2. Line Speed Signal Scaling

- Monitor TP10, Scaled Line Signal. With zero volts line speed signal applied, adjust P12 for a

reading of zero volts. Start and run the line at maximum speed. Adjust P1 for -10 volts.  
NOTE: The next two steps call for running the winder at a particular speed setting. This can be done by temporarily converting the motor control back to velocity mode and controlling it directly from a speed pot - not the CTCW board.

### 3. Winder Speed Signal Scaling

- Monitor TP8, Scaled Winder Signal. With an empty core loaded on the winder, start the winder and adjust for a core surface speed equal to the maximum line speed. With the core surface speed at maximum, adjust P15 to -10 volts.

### 4. Radius Computer

- Operate the line at maximum speed to cause -10 volts at TP10. Operate the winder at 10% speed to give -1 volt on TP8. Monitor TP24, Radius Computer, and adjust P7 to give +10 volts. Check the voltage at TP14, Diameter Signal, and verify that the +10 volts appears there.
- If applicable, convert the winder drive back to torque mode and control by the CTCW board.

### 5. Pre-Sets

- Adjust P8 to full CW and P9 and P13 to full CCW. Adjust the external TENSION pot. to minimum, full CCW.

### 6. Core Tension

- While monitoring winder armature current or web tension, start the line with the speed set to zero. Adjust P9 CW to increase the zero speed web tension to the desired level.

NOTE: In normal operation, the zero speed tension level is the sum of the Core Tension signal and any diameter signal present from an external input or from Radius Computer Memory.

### 7. Friction Compensation

- Run the line at maximum speed. While measuring the core surface speed, increase P11 until the speed is equal to or slightly greater than the line speed. Use care to supply only enough signal to reach line speed.

### 8. Inertia Compensation

NOTE: The following adjustments are made to match the acceleration rate of the winder to the accel rate of the line by compensating for inertia. This can be done easily by using a dual trace oscilloscope (preferably storage type) to com-

pare the line and winder speed signals (TP10 and TP8 respectively) during acceleration.  
NOTE: In lieu of this, material can be loaded on the line and watched during acceleration. Slackening of the web indicates too little compensation while tightening indicates too much.

### Fixed supply - J3 in the FIXED position

- While monitoring the line and winder speeds, repeat start and stop cycles and adjust P13 and P14 to match accel times. During acceleration, while compensating torque is being supplied, the LED indicator I2 will light with an intensity that is proportional to the inertia compensating signal. Clockwise rotation of both pots will increase the signal. P13 provides a coarse trim of the overall signal and P14 gives a finer adjustment to the R-C network that is differentiating the line signal.

### Diameter dependent supply - J3 in the Dia.Dep. position

- With some materials, inertia can increase considerably ( a square function) with an increase in roll diameter. For these type materials the required inertia comp. is usually very low until the point in the roll diameter where the inertia starts climbing at an exponential rate.
- The diameter dependent supply tries to compensate for this characteristic by providing a signal that will increase in proportion to the diameter until the P10 set-point is reached when it will increase exponentially with further diameter increase. P10 can be set at any diameter.

### 9. Operational Checks

- Material should now be loaded in the "line" and winder. Verify proper tension through acceleration up to and at line speed. The torque signals being adjusted up to this point are compensation for constant and repeatable loads due to the inertia and friction characteristics of the winder mechanics and the small diameter of the core.
- As diameter begins to increase due to material build-up, the tension will fall off because the external TENSION pot that sets the amount of diameter compensation was adjusted to minimum in Step 5.

### 10. Tension and Tension Range Pot Adjustment

- The actual "constant tension" torque requirement will depend on the product being wound and can be externally adjusted by the machine operator with the Tension pot. The maximum Tension is set by pot P4, Dia/Torque Level. It's amount or percentage of control is set by P8,

Tension Range and can span from 100% to approximately 17% of the diameter related torque increase. The greatest percentage is given when P8 is adjusted to full CW.

### 100% External "Tension" Range

- Preset P8 to full CW and P4 to full CCW. Adjust Tension to full CW.
- Operate the line and winder at a slow speed. When decreasing tension becomes apparent, gradually rotate P4 CW until the desired level is reached or slightly passed. Monitor web tension until total roll diameter is 2 or 3 times core diameter. Since the CTCW will continue to increase torque proportionately to diameter, further adjustment of the Tension pot should not be required for constant tension operation.

### Limited External Tension Range

- When a limited Tension trim range is desired, initially adjust P8 to full CCW. Rotate the Tension pot to full CW.
- Operate the winder and adjust P4 until desired tension is reached or slightly passed. While still running the winder, adjust Tension to full CCW – web tension should decrease approximately 17%. For more external Tension range, gradually rotate P8 CW until the minimum tension reaches the desired level.

## 11. Taper Tension

- In many winder applications, the best rolls are "built" when tension is highest at the core and mid-diameter and falls or tapers off during the remaining diameter increase. P3 can set the point where Taper Tension begins and is indicated by LED I6. The amount of tapering torque is set by P2 and is proportional to diameter.
- These pots are usually adjusted by winding material far enough to get a "feel" for the proper tension at small diameters and the diameter measurement at which constant tension problems begin to occur. More than likely, any problem noticed at a particular diameter actually started earlier in the roll. After determining the approximate problem area, make adjustments as follows:
  - Start a new roll of material and wind until Taper is required. Adjust P3 CCW until LED I6 lights. As material is wound further, adjust P2 to control the level of Taper.
  - The exact percentage of taper torque can be measured by comparing the voltage at TP14, diameter signal, to the TP18, taper signal. The torque reference at TP14 is diameter compensating torque only and is reduced by the Taper torque signal at TP18. The summed signal appears at TP25 and is trimmed by the external Tension pot.

NOTE: The Taper LED will light normally when Tapering Torque signal is being provided by the adjustments just discussed. The LED can abnormally light when the line drive is jogged or run without the winder drive. This indicates an abnormal radius calculation where the line speed signal is being divided by zero winder speed signal; an undefined mathematical expression which saturates the radius computer output to approx. +14 volts at TP24. This signal will reset to zero in a matter of seconds after the line is stopped.

## 12. Stall Tension

- The Stall Tension signal is a torque signal set by P6. When the Stall Tension relay is energized by a contact closure at TB1-5 & 6, this circuit provides the only torque reference for the winder.
- It's intended for use as a "parking" tension mode to give a tension level at zero speed that is usually less than the Core Tension plus any diameter/torque signal.

## 13. Radius Computer Memory

- The MEMORY circuit has been disabled during the adjustment procedure by the jumper previously placed between terminals TB1-3 and 4. In most applications MEMORY is not required and the jumper can remain in place and the MEMORY RESET contact will not be required.
- Where restarting partially completed rolls is a problem, the MEMORY should be left functional. This does require resetting MEMORY before starting a new roll.

# Prints

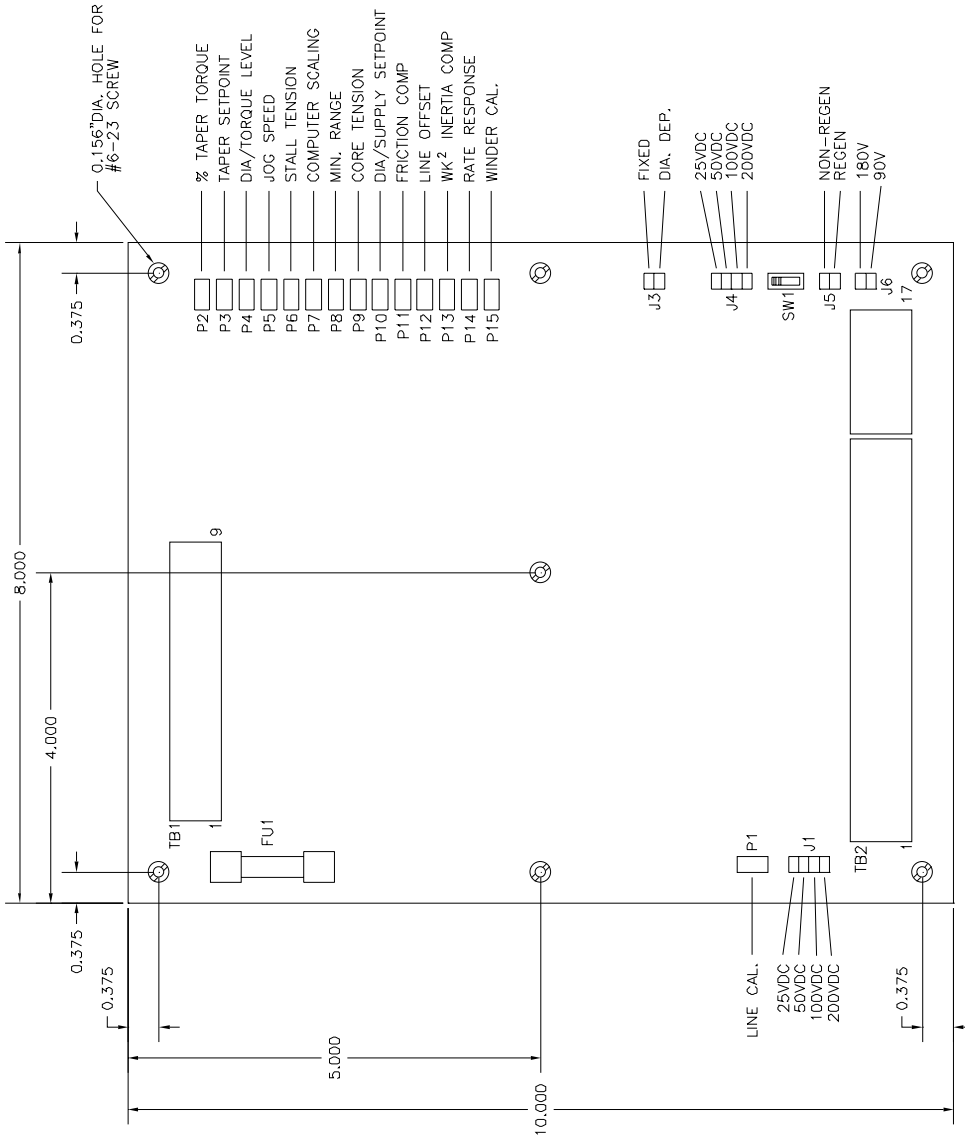

NOTES:  
 J2 (WIND/UNWIND) JUMPER DELETED AND TENSION RANGE POT  
 CHANGED TO MIN. RANGE POT 2nd QUARTER 1995.

REV. A, REDRAWN FOR MANUAL, 10-31-96

DESIGN NO.	DATE	BY	DATE
1033196	10/31/96	HJH	
APPROVED BY:			
<b>CAROTRON</b> <i>Driven by Excellence</i>			
HEATH SPRINGS, SC P.O. BOX 585-063 FAY, NC 28520-063			
DRAWING NUMBER		REV.	
<b>C10432</b>		<b>SH 1 DF 1</b>	
TITLE: DIMENSION/JUMPER POT LAYOUT CTCW			

REV. D, REVISED FOR MANUAL, 10-29-96  
 REV. C, REVISED FOR 3-22-95

DATE: 5-16-95

APPROVED BY: HJH

DESIGNED BY: HJH

DATE: 5-16-95

REVISIONS: 1

2

3

4

5

REV. D  
 D10337-000  
 REV. D  
 SH. 1 OF 1



ASSEMBLY CONTROL BOARD

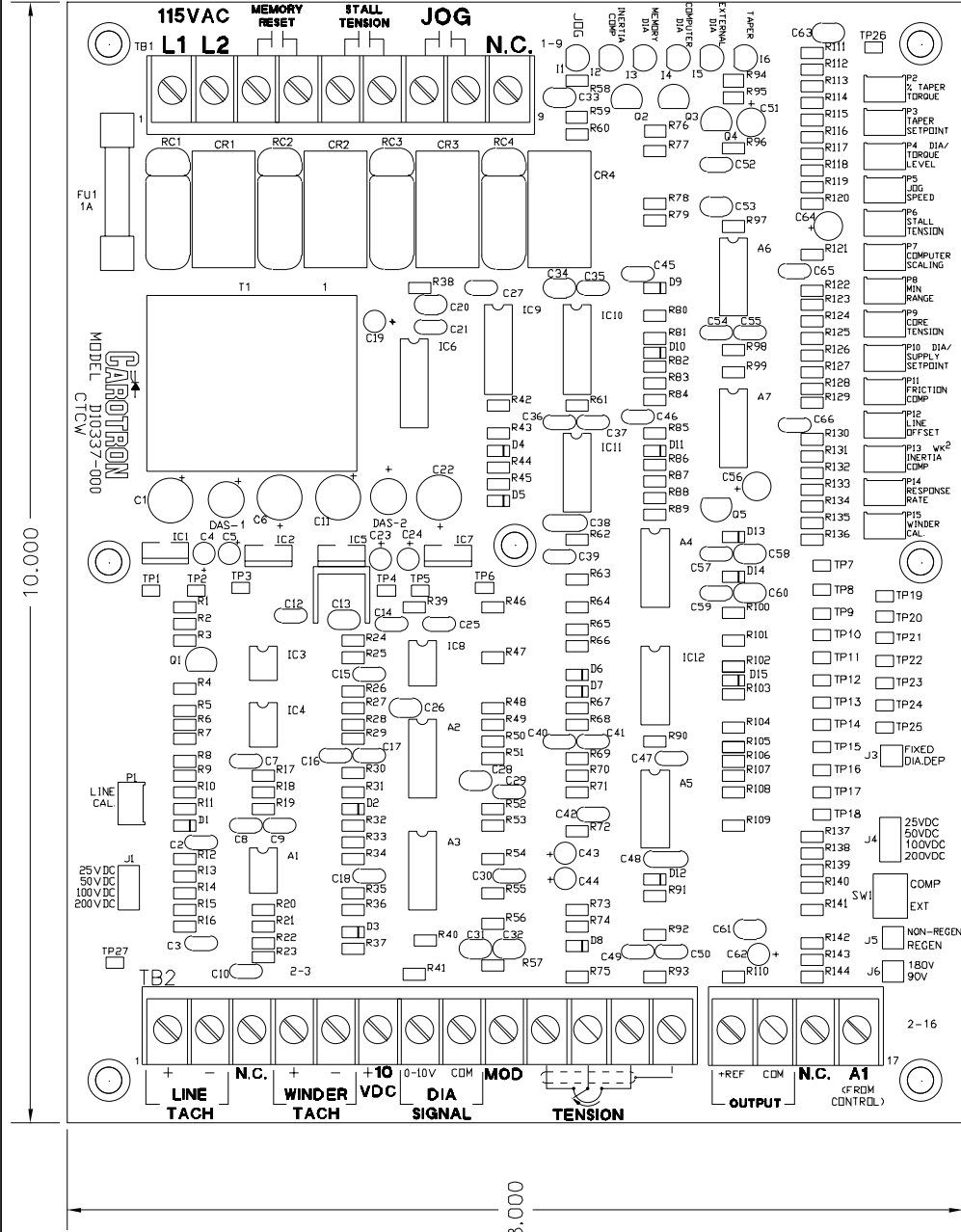

NOTES:  
 1. REF. SCHEMATIC D10335  
 2. REF. B.O.M. A10337

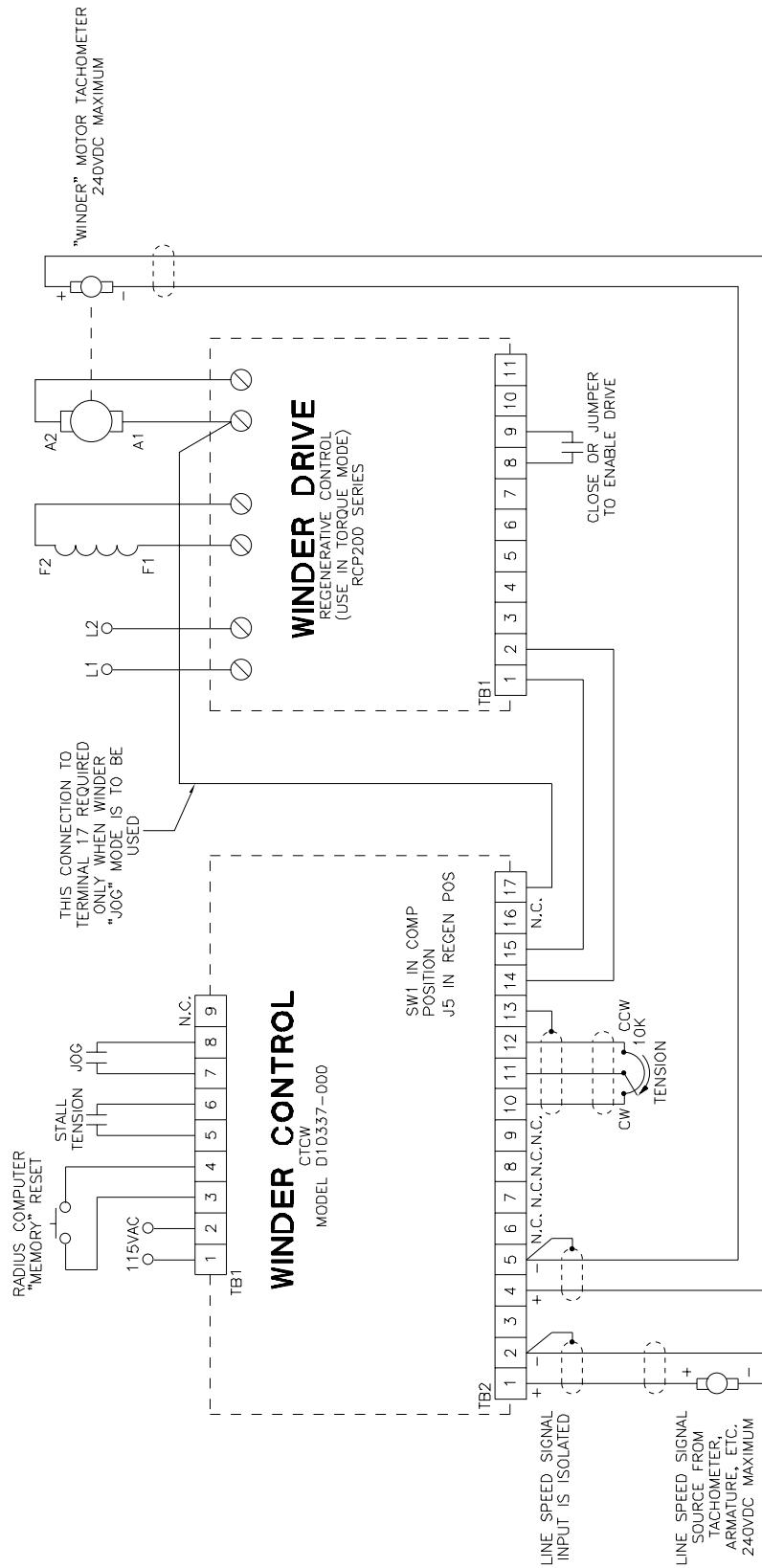

- NOTES:
1. CONNECT SHIELDS AT CONTROL END ONLY. CLIP AND INSULATE AT OTHER END.
  2. REFER TO DRIVE INSTRUCTION MANUAL FOR AC POWER AND MOTOR PROGRAMMING.

REV. D, REDRAWN FOR MANUAL, 10-30-96

DRAWN BY: HJH DATE: 10-30-96  
 APPROVED BY: DATE:

TOLERANCES: ± .001  
 UNLESS SHOWN OTHERWISE  
 3 DEC. PL. = .003



HEATH SPRINGS, SC  
 TEL: 803-286-8614  
 FAX: 803-286-6063

TITLE: CONNECTIONS  
 CTCW AND RCP200 SERIES  
 REGEN CONTROL

DRAWING NUMBER: **C10373** REV. SH. **1** OF **1**





# Standard Terms & Conditions of Sale

## 1. General

The Standard Terms and Conditions of Sale of Carotron, Inc. (hereinafter called "Company") are set forth as follows in order to give the Company and the Purchaser a clear understanding thereof. No additional or different terms and conditions of sale by the Company shall be binding upon the Company unless they are expressly consented to by the Company in writing. The acceptance by the Company of any order of the Purchaser is expressly conditioned upon the Purchaser's agreement to said Standard Terms and Conditions. The acceptance or acknowledgement, written, oral, by conduct or otherwise, by the Company of the Purchaser's order shall not constitute written consent by the Company to addition to or change in said Standard Terms and Conditions.

## 2. Prices

Prices, discounts, allowances, services and commissions are subject to change without notice. Prices shown on any Company published price list and other published literature issued by the Company are not offers to sell and are subject to express confirmation by written quotation and acknowledgement. All orders of the Purchaser are subject to acceptance, which shall not be effective unless made in writing by an authorized Company representative at its office in Heath Springs, S.C. The Company may refuse to accept any order for any reason whatsoever without incurring any liability to the Purchaser. The Company reserves the right to correct clerical and stenographic errors at any time.

## 3. Shipping dates

Quotation of a shipping date by the Company is based on conditions at the date upon which the quotation is made. Any such shipping date is subject to change occasioned by agreements entered into previous to the Company's acceptance of the Purchaser's order, governmental priorities, strikes, riots, fires, the elements, explosion, war, embargoes, epidemics, quarantines, acts of God, labor troubles, delays of vendors or of transportation, inability to obtain raw materials, containers or transportation or manufacturing facilities or any other cause beyond the reasonable control of the Company. In no event shall the Company be liable for consequential damages for failure to meet any shipping date resulting from any of the above causes or any other cause.

In the event of any delay in the Purchaser's accepting shipment of products or parts in accordance with scheduled shipping dates, which delay has been requested by the Purchaser, or any such delay which has been caused by lack of shipping instructions, the Company shall store all products and parts involved at the Purchaser's risk and expense and shall invoice the Purchaser for the full contract price of such products and parts on the date scheduled for shipment or on the date on which the same is ready for delivery, whichever occurs later.

## 4. Warranty

The Company warrants to the Purchaser that products manufactured or parts repaired by the Company, will be free, under normal use and maintenance, from defects in material and workmanship for a period of one (1) year after the shipment date from the Company's factory to the Purchaser. The Company makes no warranty concerning products manufactured by other parties.

As the Purchaser's sole and exclusive remedy under said warranty in regard to such products and parts, including but not limited to remedy for consequential damages, the Company will at its option, repair or replace without charge any product manufactured or part repaired by it, which is found to the Company's satisfaction to be so defective; provided, however, that (a) the product or part involved is returned to the Company at the location designated by the Company, transportation charges prepaid by the Purchaser; or (b) at the Company's option the product or part will be repaired or replaced in the Purchaser's plant; and also provided that (c) the Company is notified of the defect within one (1) year after the shipment date from the Company's factory of the product or part so involved.

The Company warrants to the Purchaser that any system engineered by it and started up under the supervision of an authorized Company representative will, if properly installed, operated and maintained, perform in compliance with such system's written specifications for a period of one (1) year from the date of shipment of such system.

As the Purchaser's sole and exclusive remedy under said warrant in regard to such systems, including but not limited to remedy for consequential damages, the Company will, at its option, cause, without charges any such system to so perform, which system is found to the Company's satisfaction to have failed to so perform, or refund to the Purchaser the pur-

chase price paid by the Purchaser to the Company in regard thereto; provided, however, that (a) Company and its representatives are permitted to inspect and work upon the system involved during reasonable hours, and (b) the Company is notified of the failure within one (1) year after date of shipment of the system so involved.

The warranties hereunder of the Company specifically exclude and do not apply to the following:

a. Products and parts damaged or abused in shipment without fault of the Company.

b. Defects and failures due to operation, either intentional or otherwise, (1) above or beyond rated capacities, (2) in connection with equipment not recommended by the Company, or (3) in an otherwise improper manner.

c. Defects and failures due to misapplication, abuse, improper installation or abnormal conditions of temperature, humidity, abrasives, dirt or corrosive matter.

d. Products, parts and systems which have been in any way tampered with or altered by any party other than an authorized Company representative.

e. Products, parts and systems designed by the Purchaser.

f. Any party other than the Purchaser.

The Company makes no other warranties or representation, expressed or implied, of merchantability and of fitness for a particular purpose, in regard to products manufactured, parts repaired and systems engineered by it.

## 5. Terms of payment

Standard terms of payment are net thirty (30) days from date of the Company invoice. For invoice purposed, delivery shall be deemed to be complete at the time the products, parts and systems are shipped from the Company and shall not be conditioned upon the start up thereof. Amounts past due are subject to a service charge of 1.5% per month or fraction thereof.

## 6. Order cancellation

Any cancellation by the Purchaser of any order or contract between the Company and the Purchaser must be made in writing and receive written approval of an authorized Company representative at its office in Heath Springs, S.C. In the event of any cancellation of an order by either party, the Purchaser shall pay to the Company the reasonable costs, expenses, damages and loss of profit of the Company incurred there by, including but not limited to engineering expenses and expenses caused by commitments to the suppliers of the Company's subcontractors, as determined by the Company.

## 7. Changes

The Purchaser may, from time to time, but only with the written consent of an authorized Company representative, make a change in specifications to products, parts or systems covered by a purchase order accepted by the Company. In the event of any such changes, the Company shall be entitled to revise its price and delivery schedule under such order.

## 8. Returned material

If the Purchaser desires to return any product or part, written authorization thereof must first be obtained from the Company which will advise the Purchaser of the credit to be allowed and restocking charges to be paid in regard to such return. No product or part shall be returned to the Company without a "RETURN TAG" attached thereon which has been issued by the Company.

## 9. Packing

Published prices and quotations include the Company's standard packing for domestic shipment. Additional expenses for special packing or overseas shipments shall be paid by the Purchaser. If the Purchaser does not specify packing or accepts parts unpacked, no allowance will be made to the Purchaser in lieu of packing.

## 10. Standard transportation policy

Unless expressly provided in writing to the contrary, products, parts and systems are sold f.o.b. first point of shipment. Partial shipments shall be permitted, and the Company may invoice each shipment separately. Claims for non-delivery of products, parts and systems, and for damages thereto must be filed with the carrier by the Purchaser. The Company's responsibility therefor shall cease when the carrier signs for and accepts the shipment.

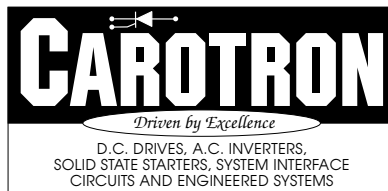

3204 Rocky River Road  
Heath Springs, SC 29058  
Phone: (803) 286-8614  
FAX: (803) 286-6063

**MAN 1022-0D**  
Issued 2-99

