

Field Economy Unit

Instruction Manual

Models

CDC3FE-001

CDC3FE-002

CDC3FE-003



Table of Contents

1. General Description	2
2. Specifications & Technical Data	2
2.1 Electrical	2
2.2 Physical	2
3. Installation	3
3.1 Circuit Protection	3
3.2 Connection information.....	3
4. Adjustment	3
5. Spare parts	4
5.1 Power components	4
5.2 Fuses	4
6. Prints	5
C10718 – Dimensions, Field Economy Board	5
C10704 – Schematic, Field Economy Board	6
C10710 – Assembly, Field Economy Board	7
C10715 – Final Assembly, Field Economy Board	8
C10717 – Connections, Field Economy Board	9

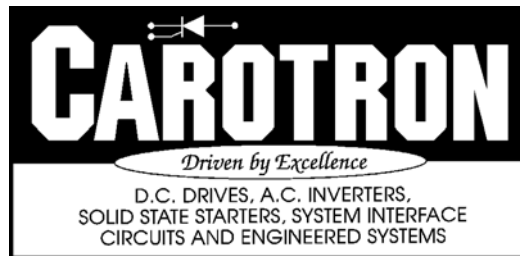

1

General Description

The Carotron Field Economy option, Model CDC3FE, is an optional field supply assembly for use with 3-phase input motor control products. Model CDC3FE is designed to reduce the level of motor field current after the motor is stopped (Stand-by).

The reduction in current will occur after an adjustable delay time and reduces destructive heating in the motor windings during long idle periods thus extending motor life. Since a percentage of the current is maintained, problems associated with cold start up, moisture build-up and speed drift are minimized.

The Model CDC3FE is easily used with a wide range of motor control products for alternate field supply voltages and the field economy function. The field economy function only requires a control contact for operation.

Features

- Adjustable time delay before field economy is activated
- Field economy activated by single contact (115 VAC Rated)
- Control circuitry operates at 115 VAC
- Control circuitry is fused at 0.3 Amps
- Oversized power handling components
- Line transient suppression on control circuit input and power input
- I.C. Regulated power supplies, metal film resistors and a cermet potentiometer for stable operation under varying conditions of temperature and line voltage
- Terminal strip provided for easy connection

2

Specifications and Technical Data

2.1 Electrical

A.C. Control Power Input

115 VAC $\pm 10\%$, 50/60 Hz ± 2 Hz

A.C. Output Current

10 Amps Max

A.C. Input/D.C. Output by Model

Model Number	A.C. Input Voltage	D.C. Output Voltage	Percent Reduction
CDC3FE-001	230/460	150/300	35%
CDC3FE-002	230	200	45%
CDC3FE-003	230	240	60%

Adjustments

Time Delay: 1 to 3 minutes

Temperature range

- Chassis: 0 to 55° C
- Enclosed: 0 to 40° C

2.2 Physical

- Refer to print C10718 in Section 6 for complete mounting dimension information on all models.

3

Installation

3.1 Circuit Protection

Model CDC3FE should be fused at 10 *Amps*. Wire size should be based on this rating in accordance with local electrical codes at each installation.

3.2 Connection Information

Refer to connection diagram C10717 in Section 6 for complete connection information.

TB1 – 1, 2 & 3 (L1, L2 & L3)

These terminals are for the A.C. input to the Field power components. Model CDC3FE-001 requires 3-phase 230 or 460 VAC input, Model CDC3FE-002 requires 1-phase 230 VAC input and model CDC3FE-003 requires 3-phase 230 VAC input. No connection is required to L3 on Model CDC3FE-002.

TB1-4 & 5 (F1 & F2)

Motor field lead F1 connects to terminal 4 and motor field lead F2 connects to terminal 5. Refer to connection diagram C10717 in Section 6 for connection to the CHOICE series of motor controls.

TB1 - 6 & 7 (Close to run)

Closing a set of contacts across these terminals will result in maximum voltage output. When the contact is opened the current will be reduced after a time delay period set by the Time Delay potentiometer.

TB1 – 8 & 9 (115 VAC Input)

These terminals are used for 115 VAC input control power. This input is fused at 0.3 *Amps* on the field economy board.

4

Adjustment

Time Delay

The Time Delay potentiometer is used to adjust the time period that the field economy circuit waits before output field current is reduced.

Opening the contact across terminals 6 & 7 starts the time delay circuit. The range of the time delay potentiometer is 1 to 3 minutes. Rotating the potentiometer clockwise increases the delay time.

5.1 Power Components

All Models

PMD1 & PMD2, SCR/diode, 25 ampere, 1400 volts
 Carotron.....PMD1010-02
 AEG/Eupec.....TD25N14KOF
 Semikron.....SKKH26/14E

Model Dependent

PMD3, dual diode, 22 ampere, 1400 volts
 Carotron.....PMD1024-00
 AEG/Eupec.....DD22S14K-K

PMD3, diode/diode, 25 ampere, 1400 volts
 Carotron.....PMD1028-00
 AGE/Eupec.....DD31N14K
 Semikron.....SKKD26/14

Power Models			
Field Economy Model	PMD1	PMD2	PMD3
CDC3FE-001	PMD1010-02	NOT USED	PMD1024-00
CDC3FE-002	PMD1010-02	NOT USED	PMD1028-00
CDC3FE-003	PMD1010-02	PMD1010-02	PMD1028-00

5.2 Fuses

FU1, 0.3 ampere, 250 volts
 CarotronFUS1005-01
 BussMDL3/10
 Littelfuse313 3/10

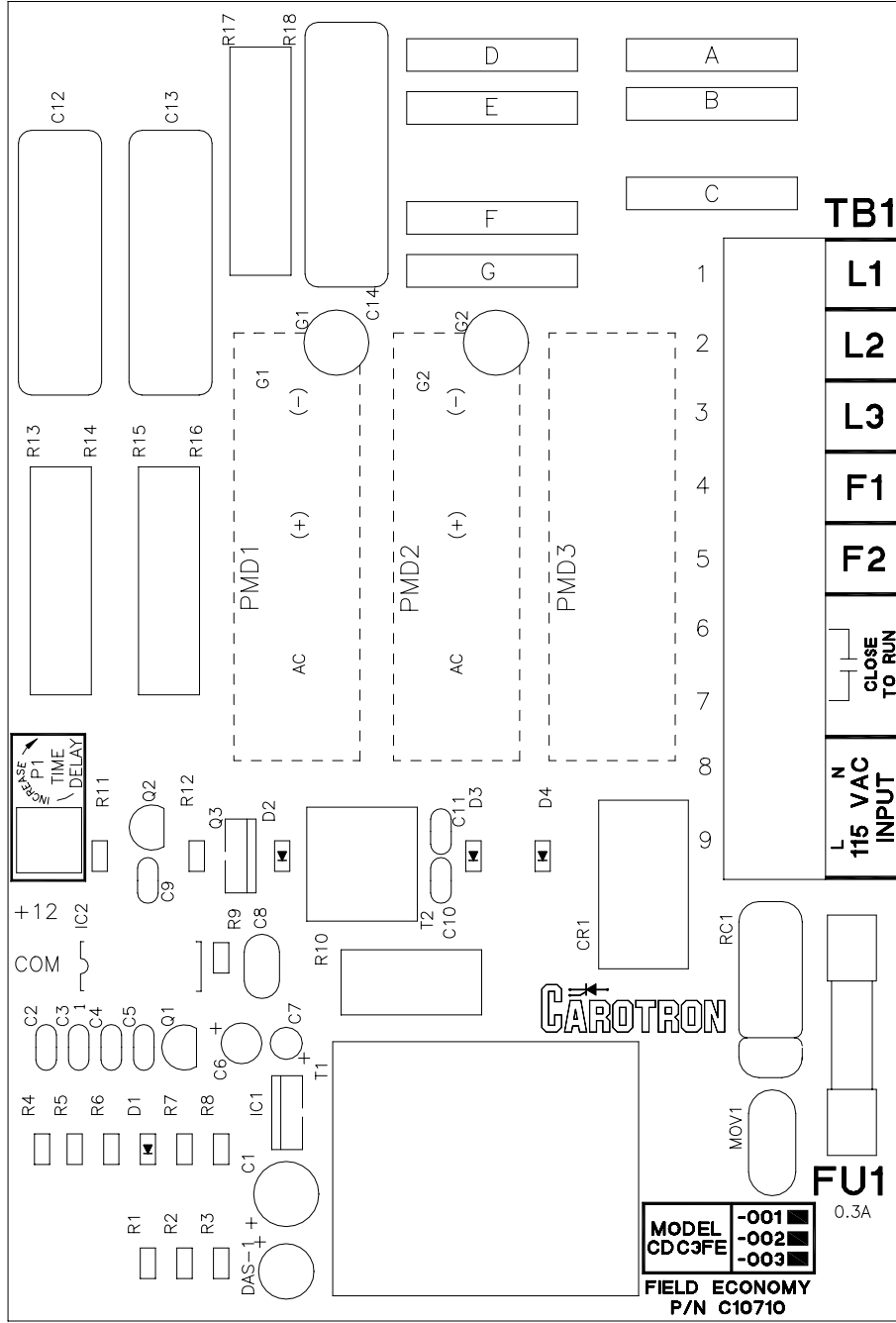

MODEL
CDC3FE

-001 ■
-002 ■
-003 ■

FIELD ECONOMY
P/N C10710

FU1
0.3A

L N
115 VAC
INPUT

8

7

6

5

4

3

2

1

9

10

11

12

13

14

15

16

17

18

19

20

21

22

23

24

25

26

27

28

29

30

31

32

33

34

35

36

37

38

39

40

41

42

43

44

45

46

47

48

49

50

51

52

53

54

55

56

57

58

59

60

61

62

63

64

65

66

67

68

69

70

71

72

73

74

75

76

77

78

79

80

81

82

83

84

85

86

87

88

89

90

91

92

93

94

95

96

97

98

99

100

L1

L2

L3

F1

F2

TO RUN

CLOSE

TB1

A

B

C

D

E

F

G

NOTES:
1. REF. SCHEM. C10704
2. REF. B.O.M. A10710

REV. A, ECO 243, 10-5-93

DATE: 10-5-93	DATE:
DRAWN BY: BKP	APPROVED BY:
CAROTRON <i>Driven by Excellence</i>	
HEATH SERVICES, SC TEL. 803-286-8614 FAX 803-286-6063	
TITLE: ASSEMBLY, FIELD ECONOMY	
SCALE: 2=1	DRAWING NUMBER: C10710
REV. A	SH. 1 OF 1

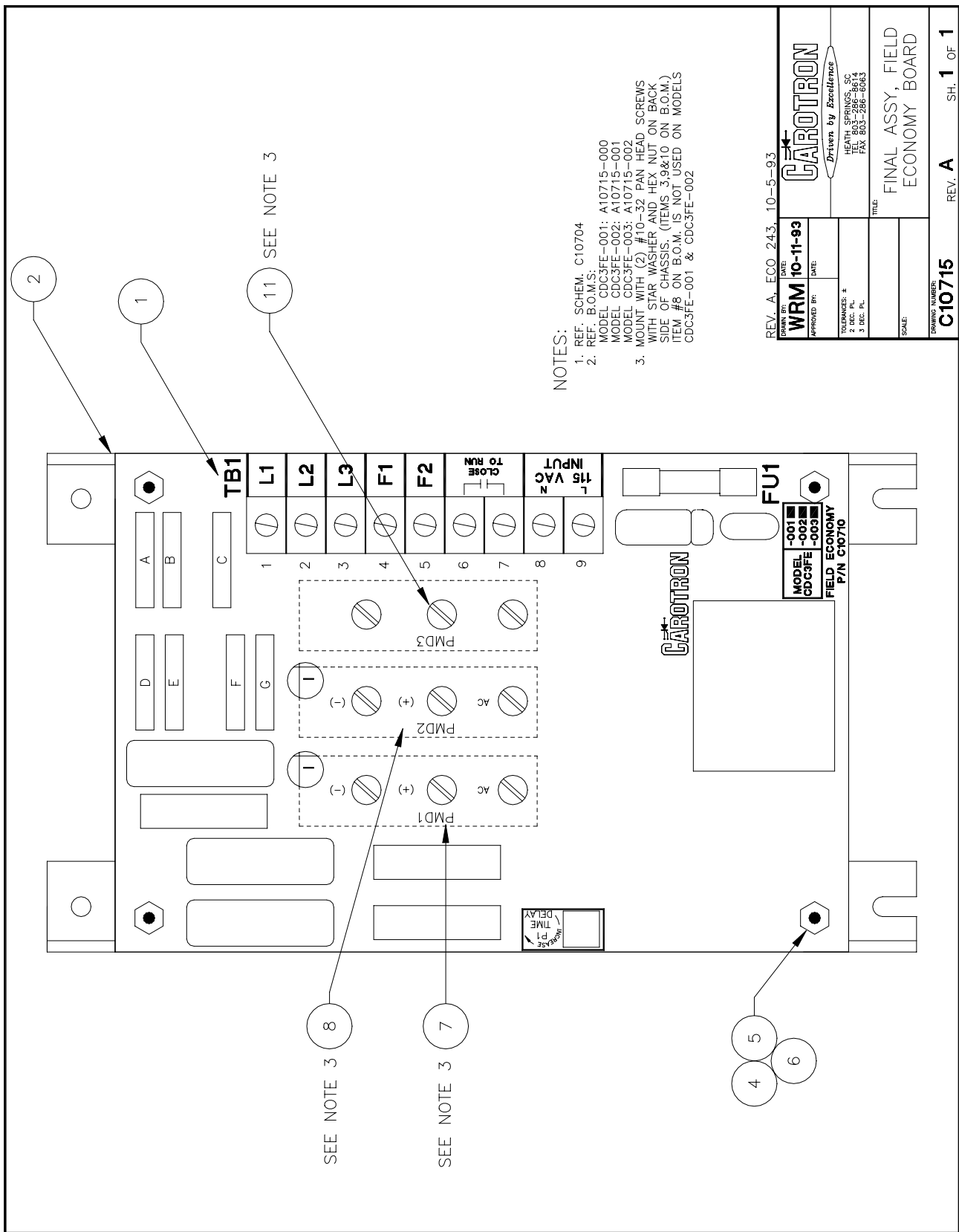

NOTES:
 1. REF. SCHEM. C10704
 2. REF. B.O.M.S.
 MODEL CDC3FE-001: A10715-000
 MODEL CDC3FE-002: A10715-001
 MODEL CDC3FE-003: A10715-002
 3. MOUNT WITH (O) #10-32 PAN HEAD SCREWS WITH STAR WASHER AND HEX NUT ON BACK SIDE OF CHASSIS. (ITEMS 3,9&10 ON B.O.M.)
 ITEM #8 ON B.O.M. IS NOT USED ON MODELS CDC3FE-001 & CDC3FE-002

REV. A, ECO 243, 10-5-93

 <i>Driven by Excellence</i>	HEALTH SPRINGS, SC 2 DEC. PL. 3 DEC. PL. FAX 803-286-8063
WRM 10-11-93 APPROVED BY: _____ DATE: _____	TITLE: FINAL ASSY, FIELD ECONOMY BOARD
DRAWING NUMBER: C10715 REV. A SH. 1 OF 1	

CONNECTIONS TO CHOICE MOTOR CONTROL

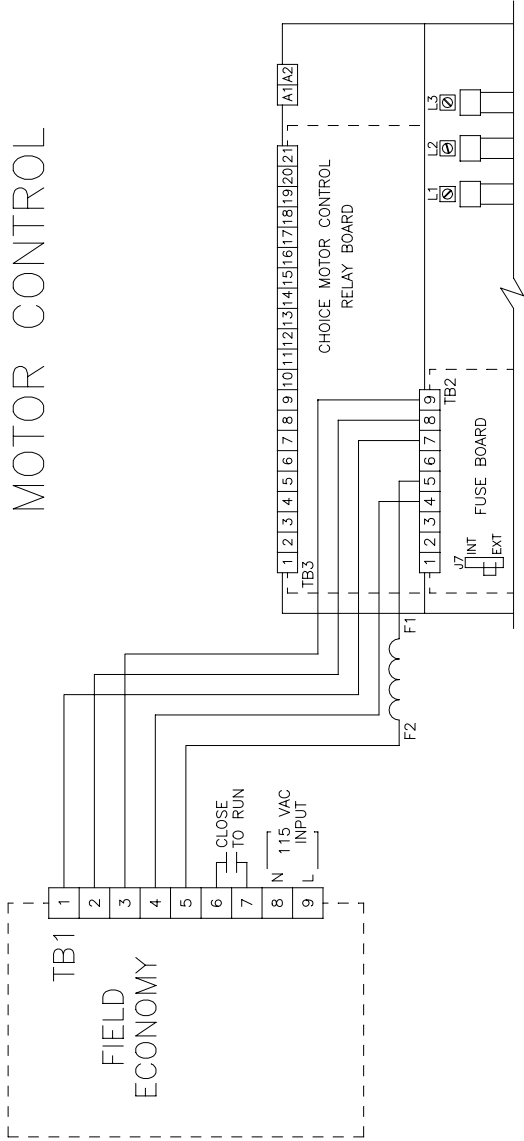

WARNING!
 J7 ON THE FUSE BOARD MUST BE PLACED IN THE EXT POSITION WHEN USING AN EXTERNAL FIELD SUPPLY/REGULATOR WITH THE CHOICE CONTROL.

- NOTES:**
- THESE CONNECTIONS INTERFACE AN EXTERNAL FIELD SUPPLY OR REGULATOR WITH THE CHOICE CONTROL FIELD LOSS CIRCUIT. THE POSITIVE FIELD CURRENT AVAILABLE AT TB2-5 IS LIMITED TO 10 AMPS BY FU2. THE VOLTAGE SUPPLY FROM TB2-7,8 AND 9 IS FUSED AT 10 AMPS BY FU4,FU5 AND FU6.

GENERAL CONNECTIONS

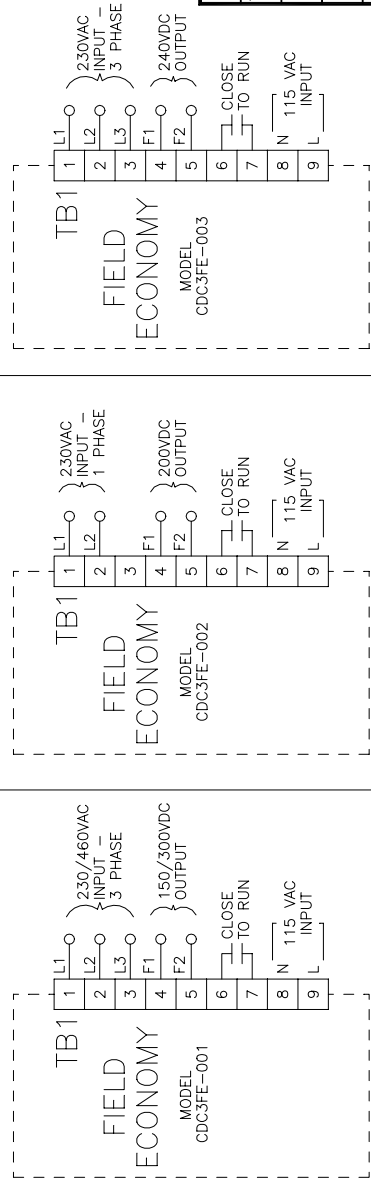

DRAWN BY: WRM	DATE: 7-8-91	
APPROVED BY:	DATE:	
TOLERANCES # 2 DEC. PL. 3 DEC. PL.		Driven by Excellence HEATH SPRINGS, SC TEL. 803-286-8614 FAX. 803-286-6063
SCALE:		TITLE: CONNECTIONS, FIELD ECONOMY BOARD
DRAWING NUMBER: C10717		REV. 1 OF 1

Standard Terms & Conditions of Sale

1. General

The Standard Terms and Conditions of Sale of Carotron, Inc. (hereinafter called "Company") are set forth as follows in order to give the Company and the Purchaser a clear understanding thereof. No additional or different terms and conditions of sale by the Company shall be binding upon the Company unless they are expressly consented to by the Company in writing. The acceptance by the Company of any order of the Purchaser is expressly conditioned upon the Purchaser's agreement to said Standard Terms and Conditions. The acceptance or acknowledgement, written, oral, by conduct or otherwise, by the Company of the Purchaser's order shall not constitute written consent by the Company to addition to or change in said Standard Terms and Conditions.

2. Prices

Prices, discounts, allowances, services and commissions are subject to change without notice. Prices shown on any Company published price list and other published literature issued by the Company are not offers to sell and are subject to express confirmation by written quotation and acknowledgement. All orders of the Purchaser are subject to acceptance, which shall not be effective unless made in writing by an authorized Company representative at its office in Heath Springs, S.C. The Company may refuse to accept any order for any reason whatsoever without incurring any liability to the Purchaser. The Company reserves the right to correct clerical and stenographic errors at any time.

3. Shipping dates

Quotation of a shipping date by the Company is based on conditions at the date upon which the quotation is made. Any such shipping date is subject to change occasioned by agreements entered into previous to the Company's acceptance of the Purchaser's order, governmental priorities, strikes, riots, fires, the elements, explosion, war, embargoes, epidemics, quarantines, acts of God, labor troubles, delays of vendors or of transportation, inability to obtain raw materials, containers or transportation or manufacturing facilities or any other cause beyond the reasonable control of the Company. In no event shall the Company be liable for consequential damages for failure to meet any shipping date resulting from any of the above causes or any other cause.

In the event of any delay in the Purchaser's accepting shipment of products or parts in accordance with scheduled shipping dates, which delay has been requested by the Purchaser, or any such delay which has been caused by lack of shipping instructions, the Company shall store all products and parts involved at the Purchaser's risk and expense and shall invoice the Purchaser for the full contract price of such products and parts on the date scheduled for shipment or on the date on which the same is ready for delivery, whichever occurs later.

4. Warranty

The Company warrants to the Purchaser that products manufactured or parts repaired by the Company, will be free, under normal use and maintenance, from defects in material and workmanship for a period of one (1) year after the shipment date from the Company's factory to the Purchaser. The Company makes no warranty concerning products manufactured by other parties.

As the Purchaser's sole and exclusive remedy under said warranty in regard to such products and parts, including but not limited to remedy for consequential damages, the Company will at its option, repair or replace without charge any product manufactured or part repaired by it, which is found to the Company's satisfaction to be so defective; provided, however, that (a) the product or part involved is returned to the Company at the location designated by the Company, transportation charges prepaid by the Purchaser; or (b) at the Company's option the product or part will be repaired or replaced in the Purchaser's plant; and also provided that (c) the Company is notified of the defect within one (1) year after the shipment date from the Company's factory of the product or part so involved.

The Company warrants to the Purchaser that any system engineered by it and started up under the supervision of an authorized Company representative will, if properly installed, operated and maintained, perform in compliance with such system's written specifications for a period of one (1) year from the date of shipment of such system.

As the Purchaser's sole and exclusive remedy under said warrant in regard to such systems, including but not limited to remedy for consequential damages, the Company will, at its option, cause, without charges any such system to so perform, which system is found to the Company's satisfaction to have failed to so perform, or refund to the Purchaser the purchase price paid by the Purchaser to the Company in

regard thereto; provided, however, that (a) Company and its representatives are permitted to inspect and work upon the system involved during reasonable hours, and (b) the Company is notified of the failure within one (1) year after date of shipment of the system so involved.

The warranties hereunder of the Company specifically exclude and do not apply to the following:

a. Products and parts damaged or abused in shipment without fault of the Company.

b. Defects and failures due to operation, either intentional or otherwise, (1) above or beyond rated capacities, (2) in connection with equipment not recommended by the Company, or (3) in an otherwise improper manner.

c. Defects and failures due to misapplication, abuse, improper installation or abnormal conditions of temperature, humidity, abrasives, dirt or corrosive matter.

d. Products, parts and systems which have been in any way tampered with or altered by any party other than an authorized Company representative.

e. Products, parts and systems designed by the Purchaser.

f. Any party other than the Purchaser.

The Company makes no other warranties or representation, expressed or implied, of merchantability and of fitness for a particular purpose, in regard to products manufactured, parts repaired and systems engineered by it.

3. Terms of payment

Standard terms of payment are net thirty (30) days from date of the Company invoice. For invoice purposed, delivery shall be deemed to be complete at the time the products, parts and systems are shipped from the Company and shall not be conditioned upon the start up thereof. Amounts past due are subject to a service charge of 1.5% per month or fraction thereof.

6. Order cancellation

Any cancellation by the Purchaser of any order or contract between the Company and the Purchaser must be made in writing and receive written approval of an authorized Company representative at its office in Heath Springs, S.C. In the event of any cancellation of an order by either party, the Purchaser shall pay to the Company the reasonable costs, expenses, damages and loss of profit of the Company incurred there by, including but not limited to engineering expenses and expenses caused by commitments to the suppliers of the Company's subcontractors, as determined by the Company.

7. Changes

The Purchaser may, from time to time, but only with the written consent of an authorized Company representative, make a change in specifications to products, parts or systems covered by a purchase order accepted by the company. In the event of any such changes, the Company shall be entitled to revise its price and delivery schedule under such order.

8. Returned material

If the Purchaser desires to return any product or part, written authorization thereof must first be obtained from the Company which will advise the Purchaser of the credit to be allowed and restocking charges to be paid in regard to such return. No product or part shall be returned to the Company without a "RETURN TAG" attached thereon which has been issued by the Company.

9. Packing

Published prices and quotations include the Company's standard packing for domestic shipment. Additional expenses for special packing or overseas shipments shall be paid by the Purchaser. If the Purchaser does not specify packing or accepts parts unpacked, no allowance will be made to the Purchaser in lieu of packing.

10. Standard transportation policy

Unless expressly provided in writing to the contrary, products, parts and systems are sold f.o.b. first point of shipment. Partial shipments shall be permitted, and the Company may invoice each shipment separately. Claims for non-delivery of products, parts and systems, and for damages thereto must be filed with the carrier by the Purchaser. The Company's responsibility therefor shall cease when the carrier signs for and accepts the shipment.

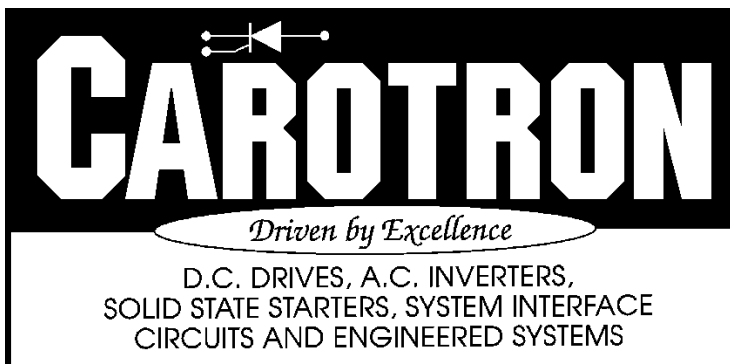

3204 Rocky River Road
Heath Springs, SC 29058
Phone: (803) 286-8614
Fax: (803) 286-6063
Email: saleserv@carotron.com
Web: www.carotron.com
MAN1009-0C
Issued 10-13-2004