

Precision Frequency To Voltage Converter Card

Instruction Manual

Model C11451-000



Table of Contents

1. General Description	3
2. Specifications	3
3. Description of Jumpers & Adjustments	4
4. Jumper Selection Procedure.	4
5. Adjustment Procedure.	5
5.1 D. C. Tachometer Feedback Signal	7
5.2 Frequency Follower	8
6. Prints.	7
6.1 C11609 - Dimension Drawing.	7
6.2 C11451 - Assembly Drawing	8
6.3 C11449 -Schematic Drawing.	9
6.4 C11610 - Connection Diagram	10



3204 Rocky River Road
Heath Springs, SC 29058
Phone: (803) 286-8614
FAX: (803) 286-6063

1 General Description

Model C11451-000 Precision Frequency to Voltage card is designed to provide a means of converting digital encoder frequency signals to analog voltage suitable for tachometer feedback control or speed reference in motor control systems. Sine wave signals of 1 to 20 volts peak at up to 30,000 Hz or square wave signals from 10 to 12 volts peak at up to 100k Hz, 50% duty cycle may be used as input (110k Hz may be used if the square wave has no more than a 25% duty cycle). The frequency signal is optically isolated from the output circuitry so that the signal may also be used with digital instrumentation which may be grounded.

Designed for use with Carotron non-regenerative and regenerative motor controls, Model C11451-000 may also be used with drives from other manufacturers if the feedback can be scaled to work with the nominal 12VDC output range. For regenerative operation, a buffered armature voltage signal must be sup-

plied for the polarity switching circuit. This voltage must be positive with respect to circuit common when the drive requires positive tach feedback and negative when the drive requires negative tach feedback.

An isolated +12VDC power supply rated at 100mA maximum is provided to supply encoders or magneto-resistor sensors. Input ranges of up to 1024 pulses per revolution on motors with a maximum speed of 6000 RPM will provide a nominal output of 0 to 12VDC. Multi-turn potentiometers for OFFSET, GAIN and BIAS are provided to allow precise adjustment for the desired output.

For systems where the output voltage is to be used as a speed reference, terminals are supplied for an optional external TRIM pot. for either manual or dancer control. A single turn TRIM RANGE pot. is supplied on the C11451-000 unit to limit the range of the external TRIM pot.

2 Specifications

AC Input

115/230 VAC $\pm 10\%$, 50/60 Hz, 9.2 VA max.

Isolation Voltage

460 VAC RMS, 1500 V peak

Linearity

$\pm 0.2\%$ of span with output range of 0 to 12VDC with a 10k Ohm load.

Signal Inputs

Square Wave:

10 to 12 V peak with 50% duty cycle at 100,000 Hz. max.

10 to 12 V peak with 25% duty cycle at 110,000 Hz. max.

Sine Wave:

1 to 20 V peak at 30,000 Hz. max.

Buffered Armature:

0 to +10 VDC maximum for positive output
0 to -10 VDC maximum for negative output

TRIM Potentiometer

An external 10k Ohm potentiometer allows the output to be trimmed. A TRIM RANGE potentiometer on the C11451-000 unit controls the TRIM pot. range from a maximum of 0 to 100% or a minimum of 83 to 100%.

Output

Typical output is 0 to ± 10 VDC for non-regen operation and -10 to +10 for regen operation. The MAX. FREQ. Jumper, J2 and the GAIN adjustment pot. allow for a wide range of input frequencies.

3 Description of Jumpers and Adjustments

Jumpers

J1 Input Wave Type: Selects between the Encoder and Magnetic Pickup inputs. In general choose the ENCODER position for square wave input signals and use terminal TB1-8 for the input. For sine wave signals, select the MAG. PICKUP position and use TB1-9 for the input.

J2 Maximum Frequency: Selects the Maximum Frequency to be used. Choose the range based on the formula given in section 4.

J3 Regen/Non-regen Selector: Allows the output voltage to be tailored for non-regen or regen feedback. In the NON- REGEN position, the output voltage is typically 0 to +10VDC. In the REGEN position, a buffered armature voltage switches the output polarity to allow the output to vary between +10VDC and -10VDC. For operation as a frequency follower, use the NON-REGEN position.

J4 Bias: Turns the BIAS pot. ON or OFF.

Potentiometers

P1 Gain

Adjusts the maximum voltage output level with maximum input signal applied.

P2 Offset

Nulls the first stage amplifier with minimum input signal applied.

P3 Bias

Biases the output up to a maximum of +5VDC. This feature is used when some minimum level of output is needed. For use in non-feedback applications only.

P4 Trim Range

Used to set the range of adjustment for the optional external TRIM pot. Using a 10,000 Ohm external TRIM potentiometer, the TRIM RANGE pot. can set the range as wide as 0 to 100% or as narrow as 83 to 100%.

Trim Potentiometer (optional)

This function is used when the unit is used as a frequency follower. The external TRIM pot. allows the output voltage to be ratioed by either a manual or dancer operated potentiometer. The range of adjustment for the external TRIM pot. is controlled by the TRIM RANGE pot. as described above.

4 Jumper Selection Procedure

The following procedure provides a method for determining which jumper positions to use for your application. Always select the proper jumper position prior to starting the adjustment procedure.

AC Voltage Input Jumpers

If 230 VAC input is to be used, jumper TB1-2 to TB1-3. If 115 VAC input is to be used, jumper TB1-1 to TB1-2 and TB1-3 to TB1-4.

J1 Selection

Select Jumper J1 based on the type of signal to be used as an input. For square wave signals, place J1 in the ENCODER position and refer to Connection Diagram D11610 for typical encoder connections. For sine wave signals, place J1 in the MAG. PICKUP position and also

refer to the connection diagram D11610 for typical magnetic pickup connections.

J2 Selection

In general, selection of J2 is related to the maximum input frequency and the desired output voltage. There are other factors involved in selecting the best setting. In the lower frequency input ranges, more signal filtering is used and response time is longer; typically 30 to 40 msec. in the 2kHz range as compared to 5 to 10 msec in the 10kHz range.

In follower or reference signal applications minimal ripple content is desirable and would prompt selection of the lowest calculated input range - refer to the following formula:

$$\frac{(\text{Maximum Rotating Speed (RPM)} \times \text{Encoder Pulses Per Revolution})}{60} = \text{Maximum Frequency in Hertz}$$

Set Jumper J2 in the range at or just above the maximum frequency.

In feedback signal applications where system stability may be dependent on fastest response, a higher range may be selected. This is particularly true where low frequency ring and gear or magnet wheel sensors, 60 and 120 PPR devices, are used on fast response drives such as many regenerative models. See the following examples where the frequency signal is converted to an analog tachometer feedback signal.

Example 1: The motor used has a 1750 RPM base speed, and a 1024 PPR encoder. Maximum frequency is $(1750 \times 1024) / 60 = 29,867$ Hz. Set J2 in 40kHz range.

Example 2: The motor used has a 1750 RPM base speed and a 60 PPR encoder. Maximum frequency is $(1750 \times 60) / 60 = 1750$. The next highest range is 2kHz, but the response time is much better in the 10kHz range, so set J2 in the 10kHz range, and increase the GAIN.

J3 Selection

Select Jumper J3 based on tach feedback operation with a non-regen or regen drive. Select the NON-REGEN position for Carotron ADP100 Series drives or other non-regen drives. Select the REGEN position for Carotron RCP200 Series drives or other regen drives.

NOTE: The regen position requires a buffered armature voltage signal on TB1-12 to control output polarity switching. This voltage must be referenced to terminal TB1-11 which is circuit common of the C11451-000 card. This armature signal must also be scaled to provide $\leq +10$ VDC maximum input when a positive output voltage is desired from the C11451-000 card and ≤ -10 VDC maximum when a negative output is desired.

For operation as a frequency follower, place jumper J4 in the non-regen position.

J4 Selection

This Jumper disables or enables the BIAS pot. The bias signal is added to the output regardless of frequency

5 Adjustment Procedure

After selecting the jumper locations following instructions in Section 4 and connecting the unit per Connection Diagram D11610, use the following information to begin adjustment of the C11451-000 Precision Frequency to Voltage Converter Card. The adjustment procedure is broken into two sections based on the type of application.

5.1 For D.C. Tachometer Feedback Signal

Step 1: Zeroing the Output

- If no external trim pot. is to be used, jumper TB1-13 to TB1-14.
- With the motor control unit disabled or the input of the C11451-000 disconnected, apply power to the C11451-000 card.
- With zero input frequency, adjust the GAIN pot (P1) full clockwise (approx. 20 turns). If an external trim pot is used, turn it full clockwise and the TRIM RANGE (P4) full counterclockwise.
- Using a voltmeter, monitor the voltage between TP1 (common) and TP4. Adjust the

OFFSET pot. (P2) until the meter reads 0.0 VDC.

- Verify that J4 is in the OFF position.
- Remove AC power from the C11451-000 card.

Step 2: Adjusting the Maximum Output For Motor Controls With Armature Feedback

- If the motor control has an armature feedback mode, select armature feedback to make the initial GAIN adjustments. If no armature feedback mode is available, go to the section labeled FOR MOTOR CONTROLS WITH TACH FEEDBACK ONLY.
- Apply AC power to the control and C11451-000 card. Start the motor and adjust for full speed. Adjust the GAIN pot (P1) for the desired output voltage between TB1-10 and TB1-11 (typically 10 VDC). Check the output voltage to be sure that the polarity is correct for feedback to the motor control. If a regenerative control is being used, make sure that the output voltage polarity is correct and switches polarity when the motor reverses.
- Stop the motor and turn off the AC power. Switch the control to the tachometer feedback mode. Turn the speed reference to minimum. Turn the max. speed adjustment on the motor control to mid-range.

- Re-apply power and start the motor. Gradually increase the speed reference to maximum. If motor speed increases rapidly or becomes uncontrolled, stop the motor and check for a bad connection or reversed polarity.
- Use the max speed pot on the motor control to set the correct speed. If max speed cannot be

- reached, decrease the feedback voltage by adjusting the GAIN pot on the C11451-000 card counter-clockwise to speed up the motor.
- NOTE: If a regenerative control is being used, make sure that the output voltage polarity is correct and switches polarity when the motor reverses.

5.2 For Frequency Follower

- If no external trim pot. is used, jumper TB1-13 to TB1-14 and skip next step.
- If an external trim adjustment is used, check connections per connection diagram D11610.

Adjust the external trim adjustment full clockwise. Adjust the TRIM RANGE adjustment (P4) for the desired range for the external trim pot. by the following chart :

TRIM RANGE Potentiometer Setting	External 10k Trim Potentiometer Range
0% Clockwise	0 to 100%
25% Clockwise	55 to 100%
50% Clockwise	71 to 100%
100% Clockwise	83 to 100%

- Apply AC power to the C11451-000 card Apply zero input or minimum input signal and adjust the GAIN pot. (P1) full clockwise (approximately 20 turns). Using a digital voltmeter, monitor the voltage between TP1 (common) and TP4.
- Adjust the OFFSET pot. (P2) until the meter reads 0.0 VDC.
- If the BIAS adjustment is not to be used, verify that J4 is in the OFF position.
- If the BIAS adjustment is to be used, set J4 in the ON position and measure the voltage from TP1 (common) to TP1-10 and set the bias level by turning the BIAS pot, P3 clock-

- wise to increase, and counterclockwise to decrease. Apply full input signal. Adjust the GAIN pot. (P1) for the desired output voltage between TB1-10 (output) and TB1-11 (common). If the desired output voltage range cannot be achieved, refer to Section 4 to make sure that the proper jumper ranges were selected.
- Check the range of the external trim pot. by monitoring the output voltage with full input frequency. Rotate the trim pot. counter clockwise. Readjust the TRIM RANGE pot. (P4) if necessary.

6 Prints

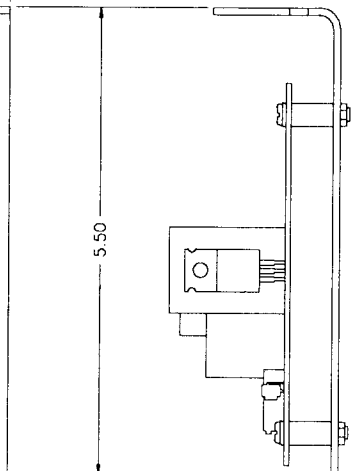
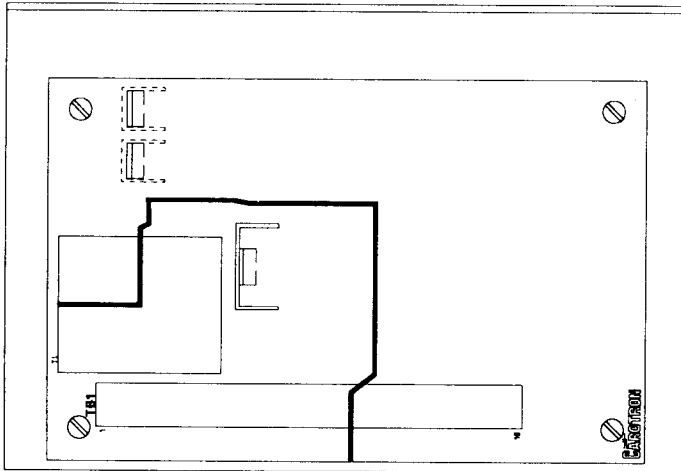
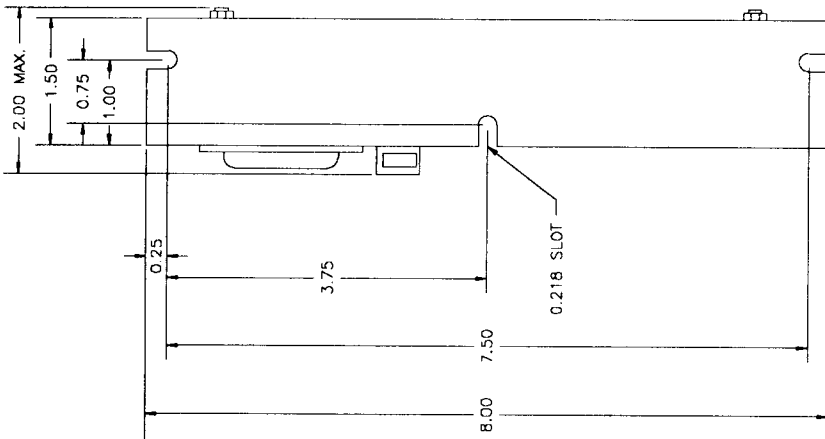

DATE	2/22/05
DESIGNED BY	UBJ
APPROVED BY	
TOLERANCES:	
1 DEC PL	.004
2 DEC PL	.005
SCALE	
DRAWING NUMBER	C11609
REV	
SH	1 OF 1



HEATH SPRINGS, SC
 TEL 803-286-8614
 FAX 803-286-8083

TITLE: DIMENSION DIAGRAM
 PRECISION
 FREQ TO VOLTAGE CARD
 MODEL C11451-000

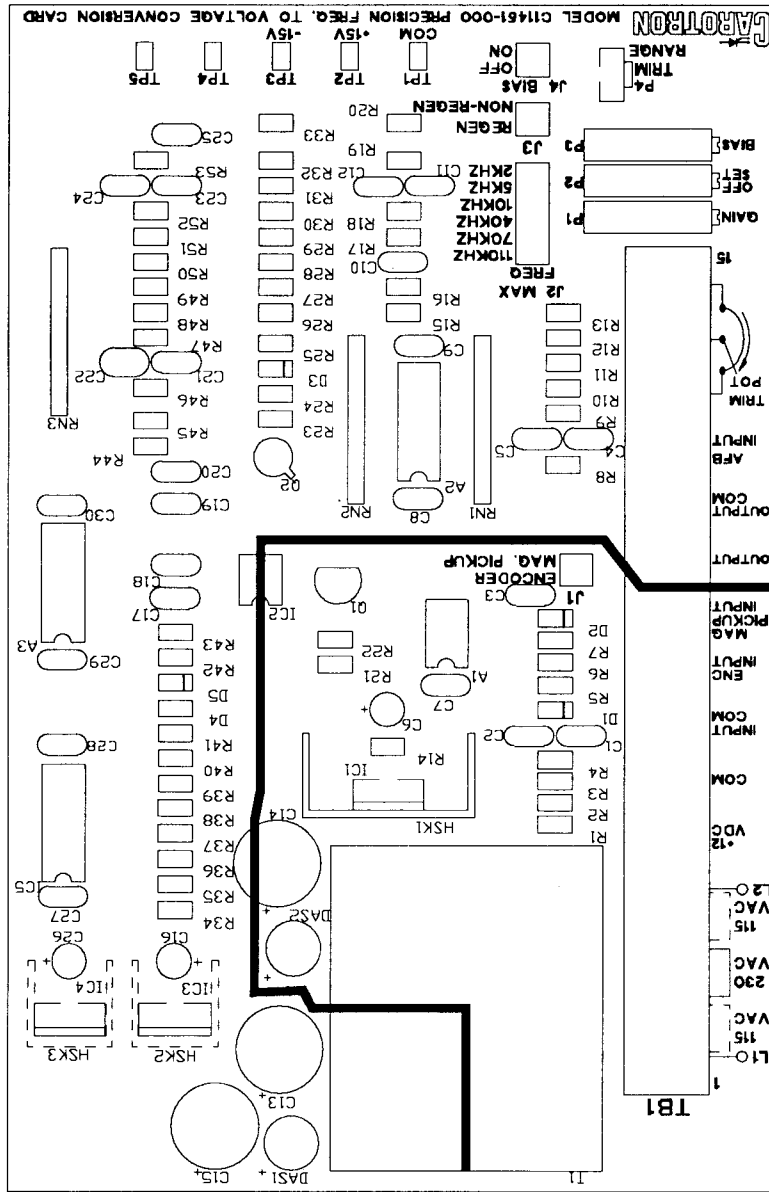

- NOTES:
1. REF. SCHEMATIC C11449
 2. REF. BOM A11451-000
 3. HSK2 & HSK3 NOT USED.

Drawn by: UBJ 10/20/84 Approved by: _____	
DATE: 10/20/84	TITLE: ASSEMBLY
TOLERANCES: 1 2 DEC. PL. 3 DEC. PL.	HEADQUARTERS: 5 HEATH SPRINGS, NC TEL: 803-285-8663 FAX: 803-285-8663
SCALE: _____	PRECISION F TO V CONVERSION CARD WITH ISOLATED OUTPUT
DRAWING NUMBER: C11451	REV. 1 OF 1

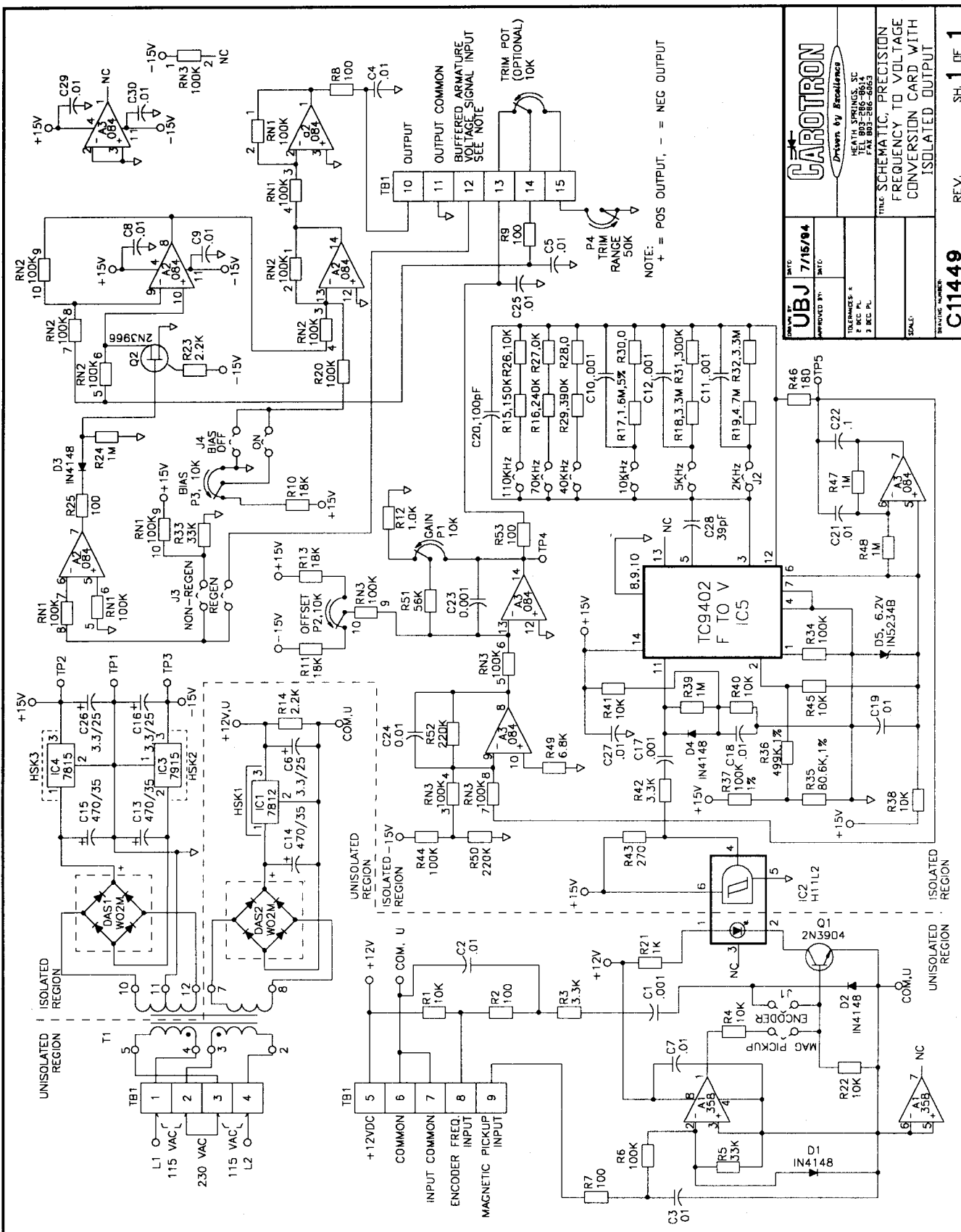

DRAWN BY: **UBJ** 7/15/84
 APPROVED BY: **BITC**
 TOLERANCES: 1/2 INCH PL.
 3 INCH PL.
 SCALE:

CAROTRON
Driven by Excellence
 HEATH SPENCER, INC.
 TEL: 803-786-8613
 FAX: 803-786-8665

TITLE: SCHEMATIC, PRECISION
 FREQUENCY TO VOLTAGE
 CONVERSION CARD WITH
 ISOLATED OUTPUT

DRAWING NUMBER: **C11449** REV. **SH. 1 OF 1**

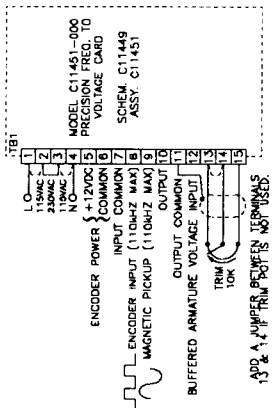

GENERAL CONNECTIONS

CONNECTION TO 300 PULSE PER REVOLUTION ENCODER WITH MAX MOTOR SPEED OF 2000 RPM

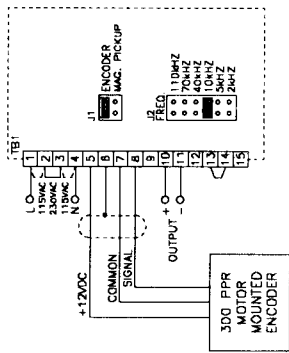

INPUT CONNECTIONS

CONNECTION TO 240 PULSE PER REVOLUTION RESOLVER OR PICKUP WITH MAX MOTOR SPEED OF 2000 RPM

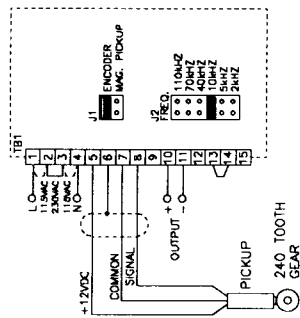

INPUT CONNECTIONS

CONNECTION TO 60 PULSE PER REVOLUTION MAGNETIC PICKUP WITH MAX MOTOR SPEED OF 2000 RPM

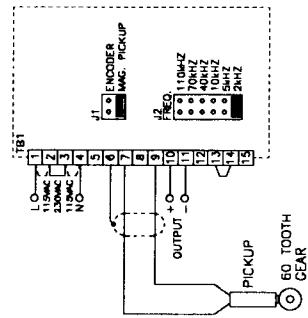

INPUT CONNECTIONS

CONNECTION TO ADP100 SERIES CONTROL FOR SPEED FEEDBACK

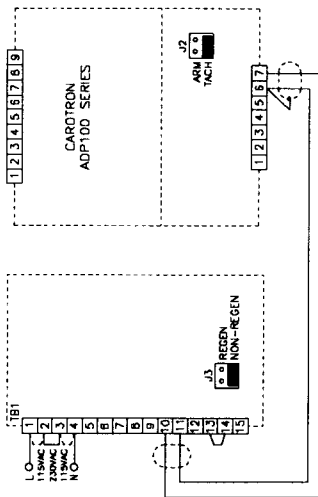

OUTPUT CONNECTIONS

CONNECTION TO RCP200 SERIES REGENERATIVE CONTROL FOR SPEED FEEDBACK

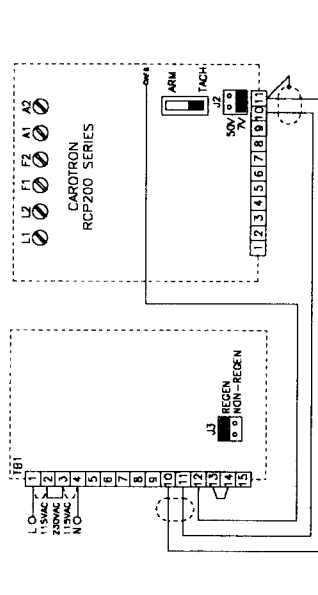

OUTPUT CONNECTIONS

CONNECTION TO RCP200 SERIES AS DIGITAL TACH FOLLOWER WITH EXTERNAL TRIM

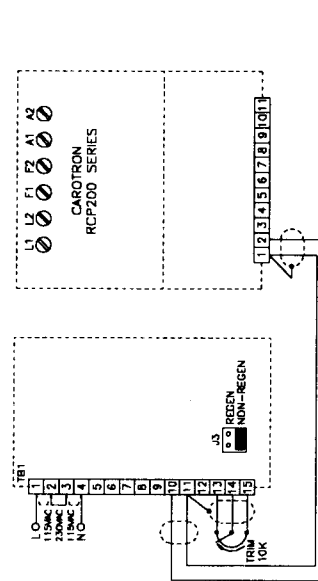

OUTPUT CONNECTIONS

CONNECTION TO ADP100 SERIES CONTROL FOR SPEED FEEDBACK

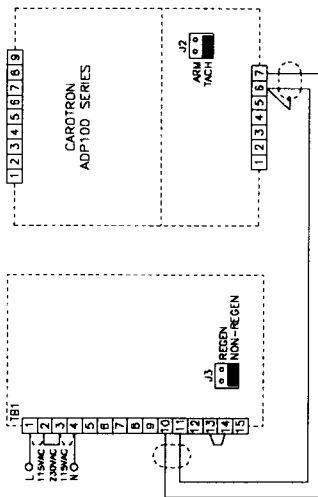

OUTPUT CONNECTIONS

CONNECTION TO RCP200 SERIES REGENERATIVE CONTROL FOR SPEED FEEDBACK

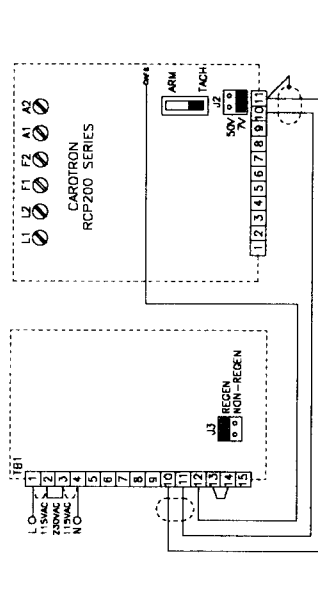

OUTPUT CONNECTIONS

CONNECTION TO RCP200 SERIES AS DIGITAL TACH FOLLOWER WITH EXTERNAL TRIM

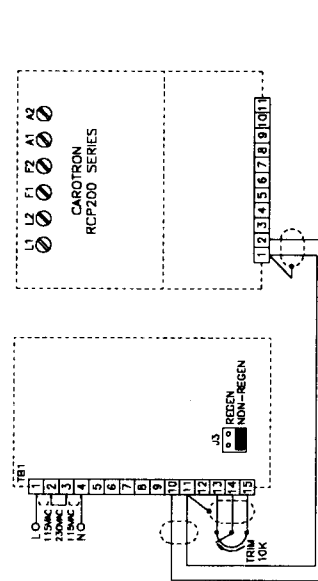

OUTPUT CONNECTIONS

MODEL C11451-000

 CONNECTION DIAGRAM

 PRECISION FREQUENCY

 TO VOLTAGE CARD

Standard Terms & Conditions of Sale

1. General

The Standard Terms and Conditions of Sale of Carotron, Inc. (hereinafter called "Company") are set forth as follows in order to give the Company and the Purchaser a clear understanding thereof. No additional or different terms and conditions of sale by the Company shall be binding upon the Company unless they are expressly consented to by the Company in writing. The acceptance by the Company of any order of the Purchaser is expressly conditioned upon the Purchaser's agreement to said Standard Terms and Conditions. The acceptance or acknowledgment, written, oral, by conduct or otherwise, by the Company of the Purchaser's order shall not constitute written consent by the Company to addition to or change in said Standard Terms and Conditions.

2. Prices

Prices, discounts, allowances, services and commissions are subject to change without notice. Prices shown on any Company published price list and other published literature issued by the Company are not offers to sell and are subject to express confirmation by written quotation and acknowledgment. All orders of the Purchaser are subject to acceptance, which shall not be effective unless made in writing by an authorized Company representative at its office in Heath Springs, S.C. The Company may refuse to accept any order for any reason whatsoever without incurring any liability to the Purchaser. The Company reserves the right to correct clerical and stenographic errors at any time.

3. Shipping dates

Quotation of a shipping date by the Company is based on conditions at the date upon which the quotation is made. Any such shipping date is subject to change occasioned by agreements entered into previous to the Company's acceptance of the Purchaser's order, governmental priorities, strikes, riots, fires, the elements, explosion, war, embargoes, epidemics, quarantines, acts of God, labor troubles, delays of vendors or of transportation, inability to obtain raw materials, containers or transportation or manufacturing facilities or any other cause beyond the reasonable control of the Company. In no event shall the Company be liable for consequential damages for failure to meet any shipping date resulting from any of the above causes or any other cause.

In the event of any delay in the Purchaser's accepting shipment of products or parts in accordance with scheduled shipping dates, which delay has been requested by the Purchaser, or any such delay which has been caused by lack of shipping instructions, the Company shall store all products and parts involved at the Purchaser's risk and expense and shall invoice the Purchaser for the full contract price of such products and parts on the date scheduled for shipment or on the date on which the same is ready for delivery, whichever occurs later.

4. Warranty

The Company warrants to the Purchaser that products manufactured or parts repaired by the Company, will be free, under normal use and maintenance, from defects in material and workmanship for a period of one (1) year after the shipment date from the Company's factory to the Purchaser. The Company makes no warranty concerning products manufactured by other parties.

As the Purchaser's sole and exclusive remedy under said warranty in regard to such products and parts, including but not limited to remedy for consequential damages, the Company will at its option, repair or replace without charge any product manufactured or part repaired by it, which is found to the Company's satisfaction to be so defective; provided, however, that (a) the product or part involved is returned to the Company at the location designated by the Company, transportation charges prepaid by the Purchaser; or (b) at the Company's option the product or part will be repaired or replaced in the Purchaser's plant; and also provided that (c) the Company is notified of the defect within one (1) year after the shipment date from the Company's factory of the product or part so involved.

The Company warrants to the Purchaser that any system engineered by it and started up under the supervision of an authorized Company representative will, if properly installed, operated and maintained, perform in compliance with such system's written specifications for a period of one (1) year from the date of shipment of such system.

As the Purchaser's sole and exclusive remedy under said warranty in regard to such systems, including but not limited to remedy for consequential damages, the Company will, at its option, cause, without charges any such system to so perform, which system is found to the Company's satisfaction to have failed to so perform, or refund to the Purchaser the pur-

chase price paid by the Purchaser to the Company in regard thereto; provided, however, that (a) Company and its representatives are permitted to inspect and work upon the system involved during reasonable hours, and (b) the Company is notified of the failure within one (1) year after date of shipment of the system so involved.

The warranties hereunder of the Company specifically exclude and do not apply to the following:

a. Products and parts damaged or abused in shipment without fault of the Company.

b. Defects and failures due to operation, either intentional or otherwise, (1) above or beyond rated capacities, (2) in connection with equipment not recommended by the Company, or (3) in an otherwise improper manner.

c. Defects and failures due to misapplication, abuse, improper installation or abnormal conditions of temperature, humidity, abrasives, dirt or corrosive matter.

d. Products, parts and systems which have been in any way tampered with or altered by any party other than an authorized Company representative.

e. Products, parts and systems designed by the Purchaser.

f. Any party other than the Purchaser.

The Company makes no other warranties or representation, expressed or implied, of merchantability and of fitness for a particular purpose, in regard to products manufactured, parts repaired and systems engineered by it.

5. Terms of payment

Standard terms of payment are net thirty (30) days from date of the Company invoice. For invoice purposed, delivery shall be deemed to be complete at the time the products, parts and systems are shipped from the Company and shall not be conditioned upon the start up thereof. Amounts past due are subject to a service charge of 1.5% per month or fraction thereof.

6. Order cancellation

Any cancellation by the Purchaser of any order or contract between the Company and the Purchaser must be made in writing and receive written approval of an authorized Company representative at its office in Heath Springs, S.C. In the event of any cancellation of an order by either party, the Purchaser shall pay to the Company the reasonable costs, expenses, damages and loss of profit of the Company incurred there by, including but not limited to engineering expenses and expenses caused by commitments to the suppliers of the Company's subcontractors, as determined by the Company.

7. Changes

The Purchaser may, from time to time, but only with the written consent of an authorized Company representative, make a change in specifications to products, parts or systems covered by a purchase order accepted by the Company. In the event of any such changes, the Company shall be entitled to revise its price and delivery schedule under such order.

8. Returned material

If the Purchaser desires to return any product or part, written authorization thereof must first be obtained from the Company which will advise the Purchaser of the credit to be allowed and restocking charges to be paid in regard to such return. No product or part shall be returned to the Company without a "RETURN TAG" attached thereon which has been issued by the Company.

9. Packing

Published prices and quotations include the Company's standard packing for domestic shipment. Additional expenses for special packing or overseas shipments shall be paid by the Purchaser. If the Purchaser does not specify packing or accepts parts unpacked, no allowance will be made to the Purchaser in lieu of packing.

10. Standard transportation policy

Unless expressly provided in writing to the contrary, products, parts and systems are sold f.o.b. first point of shipment. Partial shipments shall be permitted, and the Company may invoice each shipment separately. Claims for non-delivery of products, parts and systems, and for damages thereto must be filed with the carrier by the Purchaser. The Company's responsibility therefor shall cease when the carrier signs for and accepts the shipment.

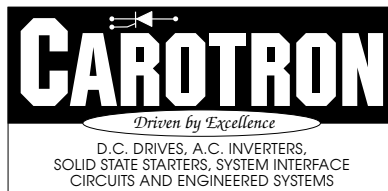

3204 Rocky River Road
Heath Springs, SC 29058
Phone: (803) 286-8614
FAX: (803) 286-6063

MAN 1027-0B
Issued 6-1-95